

INSTRUCTION MANUAL

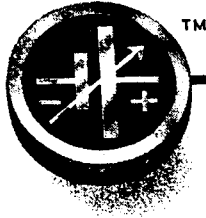

KEPCO POWER SUPPLIES



Size AA-280 Series

MODEL PRM 24-12

Please record the equipment nameplate serial number in the space provided.

Serial No.

GENERAL DESCRIPTION

The Kepeco Model PRM 280 Series of power supplies consists of the group of units listed in Table 1. The design of PRM power supplies is based on Kepeco's patented "FLUX-O-TRAN"[®] ferroresonant power transformer, which provides output voltage stabilization and output current limiting. Due to their rugged construction and low parts count, Kepeco's PRM modules are highly reliable d-c power sources, featuring efficiencies of approximately 75% at full load (See also FIG. 4).

SPECIFICATIONS, SOURCE INPUT:

- A) INPUT REQUIREMENTS: 115V a-c, $\pm 15V$, 60 Hz $\pm 5\%$, single phase, approximately 3.6A.
- B) BROWN-OUT PROTECTION: All models will maintain the output specification down to an input of 96V a-c and will function at 80% of rated loading capacity to "brown-out" source levels as low as 85V a-c.

SPECIFICATIONS, D-C OUTPUT

- A) OUTPUT RATINGS, LOAD EFFECT AND RIPPLE: (See also Fig's. 6 and 7).

MODEL	d-c OUTPUT		LOAD EFFECT VOLTS INCREASE		RIPPLE (max) RMS VOLTS
	VOLTS	AMPS	100%-50% LOAD	100%-25% LOAD	
PRM 8.5-30	8.5	0-30	0.5	0.8	0.3
PRM 12-23	12	0-23	0.5	0.8	0.3
PRM 15-18	15	0-18	0.7	1.1	0.3
PRM 24-12	24	0-12	0.8	1.25	0.3
PRM 28-10	28	0-10	0.8	1.25	0.3
PRM 48-6	48	0-6	1.2	1.8	0.4
PRM 120-2.4	120	0-2.4	2.4	4.0	0.4

TABLE 1 OUTPUT SPECIFICATIONS, PRM 280 SERIES.

NOTE: Output voltage accuracy $\pm 2\%$ or 0.25 volts, at nominal source input, full load and 30°C ambient temperature. Initial (cold) output voltage is 1% higher than the table values.

- B) SOURCE VOLTAGE EFFECT: Output varies less than $\pm 1\%$ for the rated source voltage range at full load. At no load, the source effect is $\pm 1.5\%$ maximum.
- C) SOURCE FREQUENCY EFFECT: A $\pm 1\%$ change in source frequency produces approximately $\pm 1.5\%$ of output voltage change.
- D) TIME EFFECT (8-hour drift): Less than 1% or 0.1V, whichever is greater (after initial 1/2 hour warm up).
- E) TEMPERATURE EFFECT (coefficient): Less than 0.05% per °C.
- F) DYNAMICS:
 - 1) VOLTAGE RECOVERY: The time required for the stabilized output voltage to recover within the load effect band, following a 50% load step, is 250 milliseconds typical, 400 milliseconds maximum.
 - 2) OUTPUT IMPEDANCE: The output impedance from d-c to 10 KHz is a function of the load effect:

$$Z_o = \Delta E_o / \Delta I_o$$

where ΔE_o is the change in output voltage for a given change in load current (ΔI_o). For frequencies **above** 10 KHz, the effect of a 0.5 μ H series inductance must be added.

SPECIFICATIONS, GENERAL

- A) OPERATING TEMPERATURE RANGE: -20°C to 55°C . No derating of the specified output current and no external heat sink required.
- B) STORAGE TEMPERATURE RANGE: -40°C to 85°C .
- C) ISOLATION: The circuit of the PRM modules is isolated from the chassis and from ground. It may be floated up to 600V d-c (or peak) off ground. The chassis should be grounded for safety. A common mode current of $15\mu\text{A}$ rms typical, $50\mu\text{A}$ rms maximum, $50\mu\text{A}$ p-p typical, $250\mu\text{A}$ p-p maximum, at 60 Hz, flows to the ground return of the a-c power source.
- D) WITHSTAND VOLTAGE: 1KV a-c for 1 minute, input to output or input to chassis.
- E) SERIES/PARALLEL: PRM modules can be connected in series up to the 600V isolation limit. Identical models can be paralleled for approximately double current (allow for 10% current imbalance).
- F) STANDARDS: PRM modules are designed and tested in accord with the NEMA standard for stabilized power supplies, d-c output, Publication No. PY-1-1972 AND IEC recommendation 478 (parts 1-4). All PRM models are recognized by Underwriters Laboratories under the UL Component Recognition Program: UL specifications 114 and 478.
- G) SHIPPING WEIGHT: Approximately 24 lbs. (10.9 Kg.)

SPECIFICATIONS, MECHANICAL (See "Mechanical Outline Drawing", FIG. 8)

- A) MOUNTING: Three mounting methods are illustrated in the Mechanical Outline Drawing, FIG. 8. The PRM module may also be mounted into a standard (19-inch) instrument rack by means of the following Kepco Rack Adapters:
 - 1) Single-unit Rack Adapter, Kepco Model RA 10-1. (5" Panel height)
 - 2) Two-unit Rack Adapter, Kepco Model RA 8-2. (7" Panel height)
 - 3) Three-unit Rack Adapter, Kepco Model RA 9-3. (7" Panel height)
- B) PRM 280 Series power supplies are normally sold uncased. A case is available see Kepco Model CA-200.

TERMINATIONS AND LOAD CONNECTIONS

A-C input and d-c output connections on the PRM Series 280 power supply are terminated at the barrier strip (TB1) as shown in FIG. 1. The barrier strip terminals are rated for 30 amperes and can accommodate wires to AWG #12. Load wires should be as heavy as practicable, as short as possible, and should be tightly twisted to avoid noise pick-up problems. Typical output characteristic curves for the PRM 280 Series are shown in FIG. 2. The inherent current limiting characteristic of the PRM power supply is a function of the a-c source voltage, as seen in FIG. 2. Under current limit condition, the primary current will increase as shown in the curves of FIG. 3. Power factor characteristics curves are shown in FIG. 5. The data represented in the graphs of FIG's 2. through FIG. 7 is typical for all models in the PRM 280 Series.

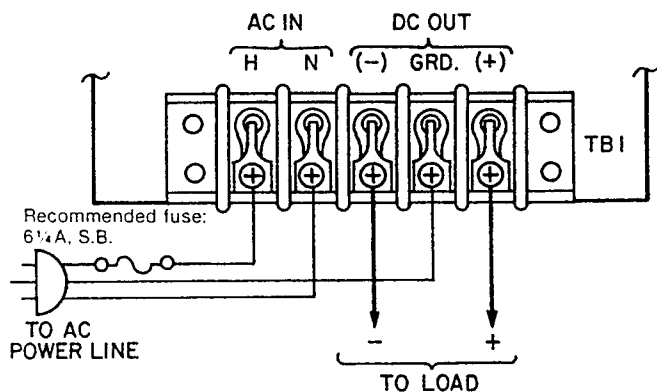

FIG. 1 TERMINATIONS AND LOAD CONNECTIONS. PRM 280 SERIES.

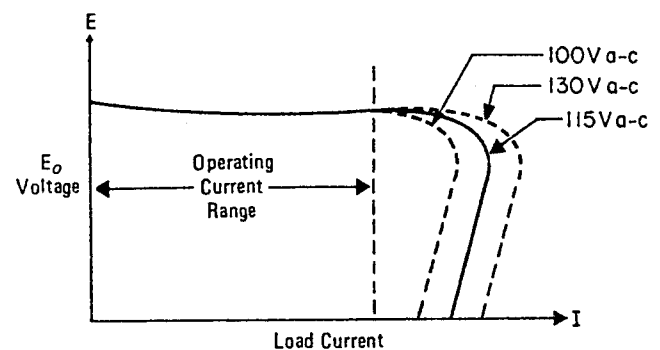

FIG. 2 TYPICAL OUTPUT VOLTAGE CHARACTERISTIC AS A FUNCTION OF LOAD CURRENT AND A-C INPUT VOLTAGE.

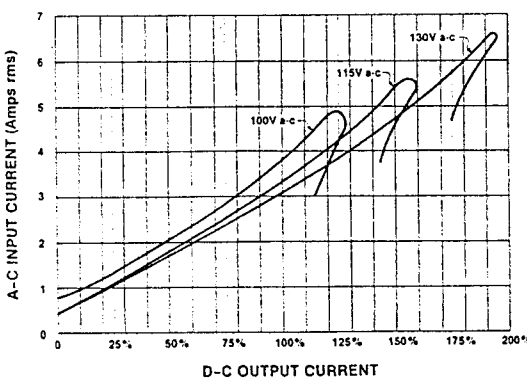

FIG. 3 A-C INPUT CURRENT vs. LOAD CURRENT FOR LOW, NOMINAL AND HIGH INPUT SOURCE.

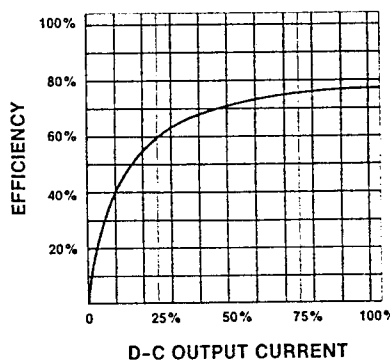

FIG. 4 EFFICIENCY vs. LOAD CURRENT

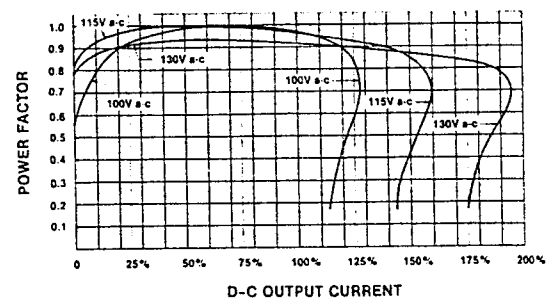

FIG. 5 POWER FACTOR vs. LOAD CURRENT FOR LOW, NOMINAL AND HIGH INPUT SOURCE

PRM 280 SERIES
TYPICAL OUTPUT RIPPLE VS. LOAD CURRENT CURVES.

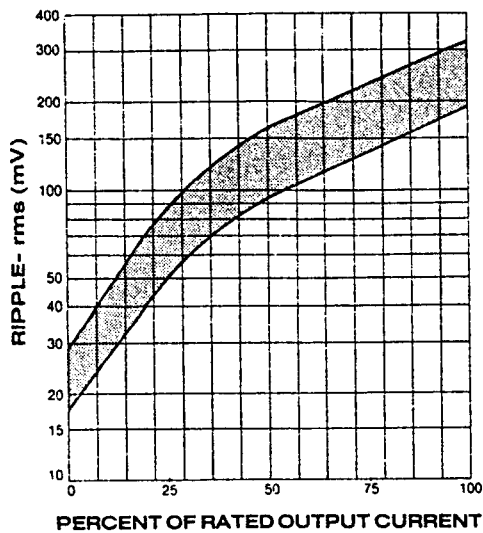

FIG. 6 TYPICAL OUTPUT RIPPLE AS A FUNCTION OF LOAD CURRENT, PRM 280 SERIES.

PRM 280 SERIES
TYPICAL LOAD EFFECT CURVES

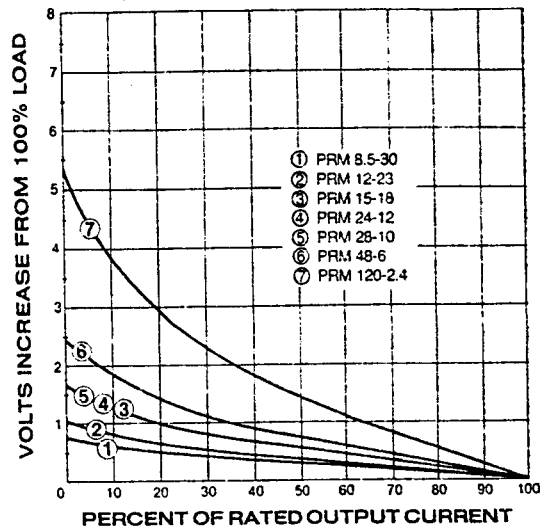
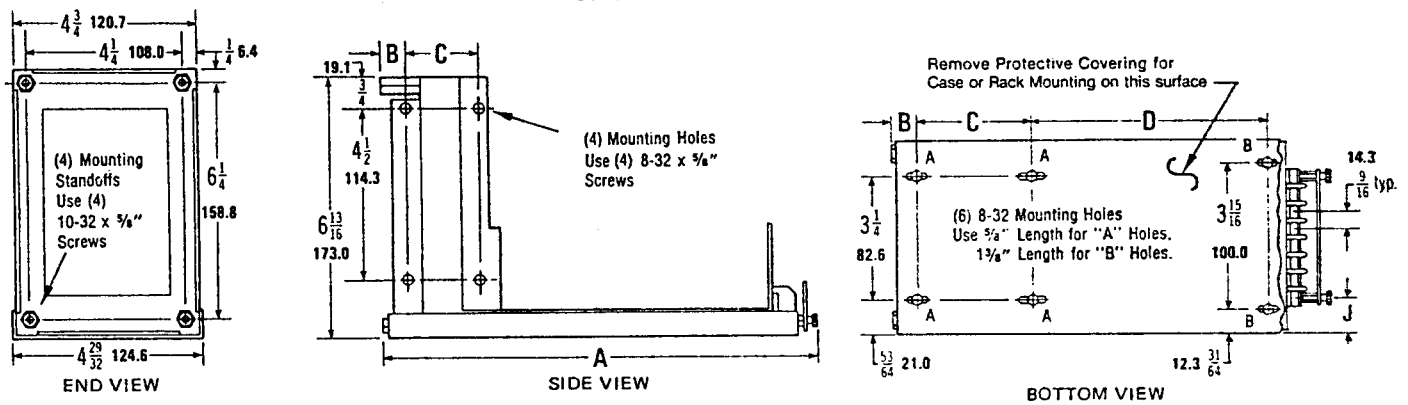

FIG. 7 TYPICAL LOAD EFFECT AS A FUNCTION OF LOAD CURRENT, PRM 280 SERIES.

UNCASED MODELS



CASED MODELS

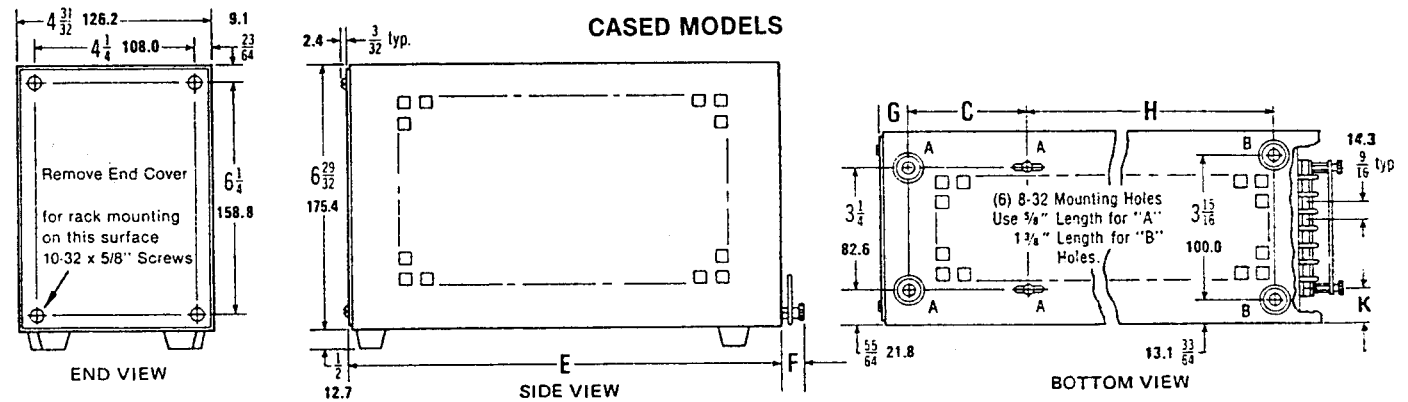

FIG. 8 MECHANICAL OUTLINE DRAWING, PRM 280 SERIES.

MODELS	A	B	C	D	E	F	G	H	J	K
PRM SIZE "AA"	10 ²⁹ / ₃₂ 277.0	1 ¹ / ₁₆ 17.5	2 ¹¹ / ₃₂ 59.5	6 1/2 165.1	10 1/2 266.7	1/2 12.7	3/4 19.1	6 1/2 165.1	4 ⁹ / ₁₆ 19.5	5 ¹ / ₁₆ 20.2

NOTES:

- 1) MATERIAL: Chassis, 16 GA-CRS; Case 16 GA-Aluminum.
- 2) FINISH: Chassis, Cadmium plated with chromate wash; Case, royal blue epoxy paint.
- 3) FRACTIONAL DIMENSIONS (Light Face Type) are in inches. DECIMAL DIMENSIONS (Bold Face Type) are in millimeters.
- 4) TOLERANCES: ± 1/64 (0.4) between mounting holes. ± 1/32 (0.8) all other dimensions.

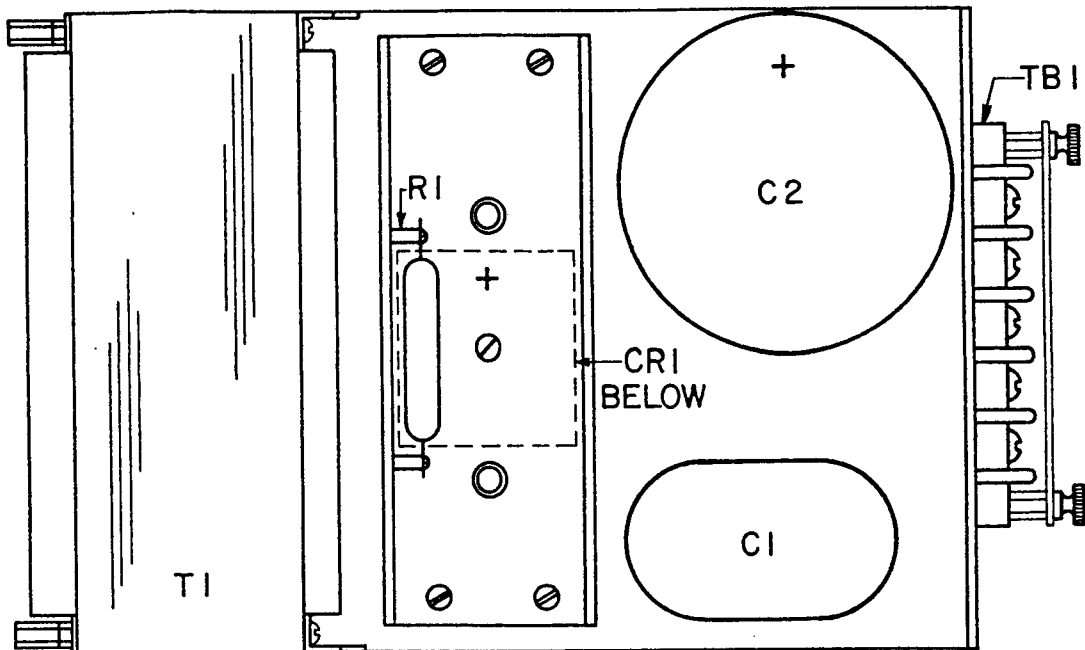

FIG. 9 COMPONENT LOCATION DIAGRAM FOR MODELS:
PRM 24-12, PRM 28-10, PRM 48-6, PRM 120-2.4.

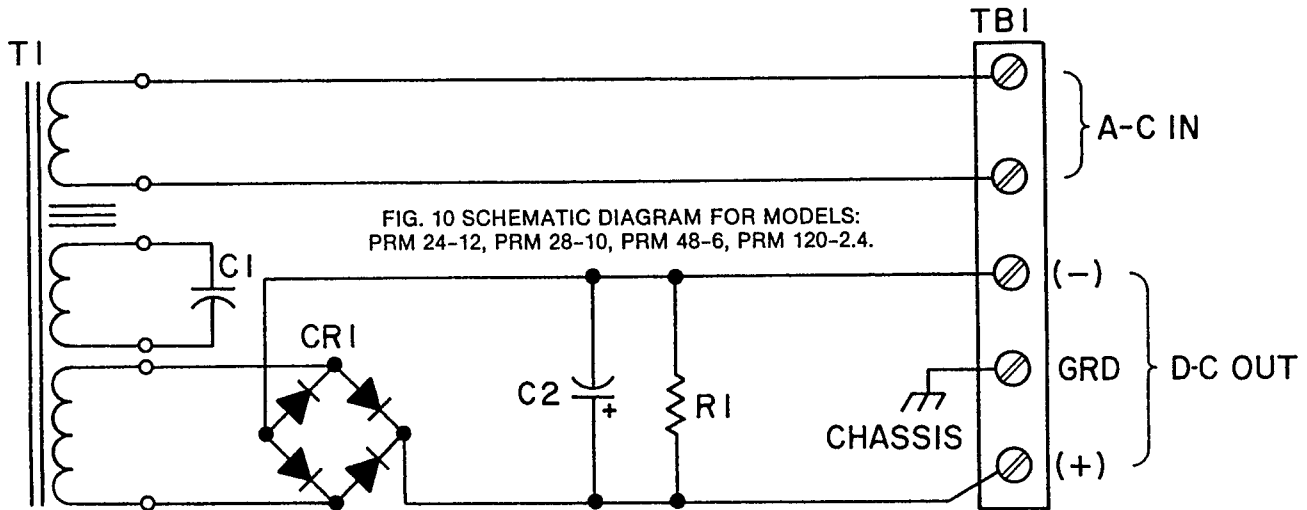

FIG. 10 SCHEMATIC DIAGRAM FOR MODELS:
PRM 24-12, PRM 28-10, PRM 48-6, PRM 120-2.4.

MODEL PRM 24-12

REPLACEMENT PARTS LIST

Code 08-3082

REFERENCE DESIGNATION	QTY.	DESCRIPTION	MFRS. NAME & PART NO. SEE BOTTOM NOTE	KEPCO PART NO.	REC. SPARE PART QTY.
C1	1	Cap., Poly/Paper, Can-Type 3 μ F, \pm 6%, 660V a-c	General Electric Type 26F	117-0928	1
C2	1	Cap., Elect., Can-Type 100K μ F, + 75 - 10%, 30V	Mepco-Electra Type 3186	117-0959	1
CR1	1	Rect., Si., Bridge 200V (PIV), 35A (T _A = 40 °C)	Motorola MDA3502	124-0476	1
R1	1	Res., Fxd., Power, Strip 30 ohm, 5%, 40W	E-Systems Type ZR40	115-1428	1
T1	1	Transformer, Power	Kepeco Inc. 100-2196	100-2196	1
TB1	1	Barrier Strip, 5-terminals	Kepeco Inc. 167-0318	167-0318	1

NOTE: REPLACEMENT PARTS MAY BE ORDERED FROM KEPCO, INC. ORDERS SHOULD INCLUDE KEPCO PART NUMBER AND DESCRIPTION.

PLEASE NOTE: THE MANUFACTURER'S NAME AND PART NUMBER LISTED FOR EACH ITEM ON REPLACEMENT PARTS LISTS REPRESENTS AT LEAST ONE SOURCE FOR THAT ITEM AND IS LISTED SOLELY FOR THE CONVENIENCE OF KEPCO EQUIPMENT OWNERS IN OBTAINING REPLACEMENT PARTS LOCALLY. WE RESERVE THE RIGHT TO USE EQUIVALENT ITEMS FROM ALTERNATE SOURCES. KEPCO, INC.